

Enrollment No: _____

Exam Seat No: _____

C.U.SHAH UNIVERSITY

Summer Examination-2019

Subject Name : Basics of Civil & Structural Engineering

Subject Code : 4TE02BCS1

Branch: B.Tech (All)

Semester: 2

Date: 02/05/2019

Time: 02:30 To 05:30

Marks: 70

Instructions:

- (1) Use of Programmable calculator & any other electronic instrument is prohibited.
- (2) Instructions written on main answer book are strictly to be obeyed.
- (3) Draw neat diagrams and figures (if necessary) at right places.
- (4) Assume suitable data if needed.

Q-1 Attempt the following questions:

(14)

- a) Define leveling.
- b) What are the three segments of GPS?
- c) Convert the WCB of 250° into RB.
- d) Enlist the types of stones.
- e) Write the functions of ingredients of cement.
- f) List out the various properties of bricks
- g) What is meant by ranging?
- h) Define Pappus– Guldinus theorem.
- i) List the Fundamental principle of mechanics.
- j) State the Law of Parallelogram of Forces.
- k) What is the purpose of drawing a free body diagram?
- l) Define center of gravity.
- m) What is radius of gyration?
- n) What is parallel axis theorem?

Attempt any four questions from Q-2 to Q-8

Q-2 Attempt all questions

- (a) Differentiate between plane surveying and geodetic surveying. **(04)**
- (b) Discuss the various classification of survey in detail. **(10)**



Q-3 Attempt all questions

- (a) What is concrete? What are the types of concrete? Explain the properties of concrete. (06)
- (b) Explain the various types of cement used for construction. (04)
- (c) Discuss the characteristics of contour with the help of neat sketches. (04)

Q-4 Attempt all questions

- (a) A 20m chain was found to be 8cm too long at the end of days work after measuring 4000m. If the chain was correct before the commencement of work, find the correct length of the line. (06)
- (b) Differentiate between prismatic compass and surveyors compass. (04)
- (c) Write short notes on the importance of sand and aggregate in construction. (04)

Q-5 Attempt all questions

- (a) Explain the various methods of seasoning of timber. (06)
- (b) Write short notes on copper with its uses and properties. (04)
- (c) Write the uses and application of GPS. (04)

Q-6 Attempt all questions

- (a) Two cables are tied together at *C* and are loaded as shown in figure 1. Knowing that $P = 500\text{ N}$ and $\alpha = 60^\circ$, determine the tension in (a) in cable *AC*, (b) in cable *BC*. (08)
- (b) Determine the resultant force of the force system shown in figure.2. (06)

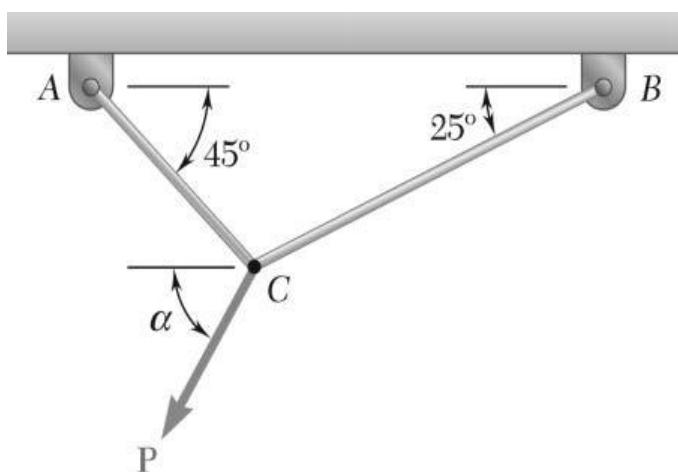

Figure.1.

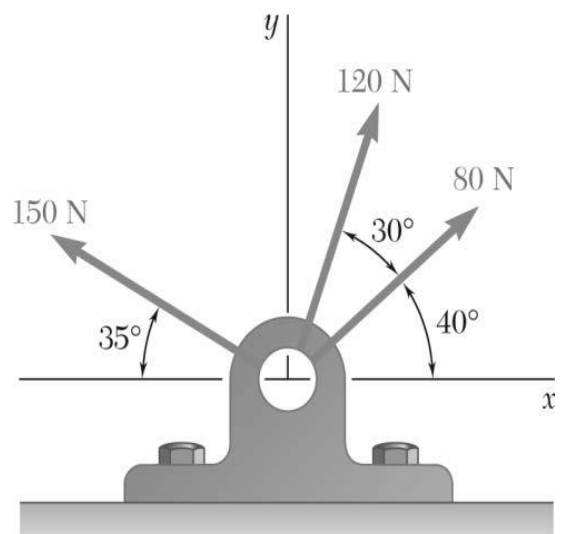

Figure.2.



Q-7

Attempt all questions

- (a) Determine the forces in all the members of the truss shown in Figure.3. All inclined members are at 60° to horizontal and length of each member is 2 m. (14)

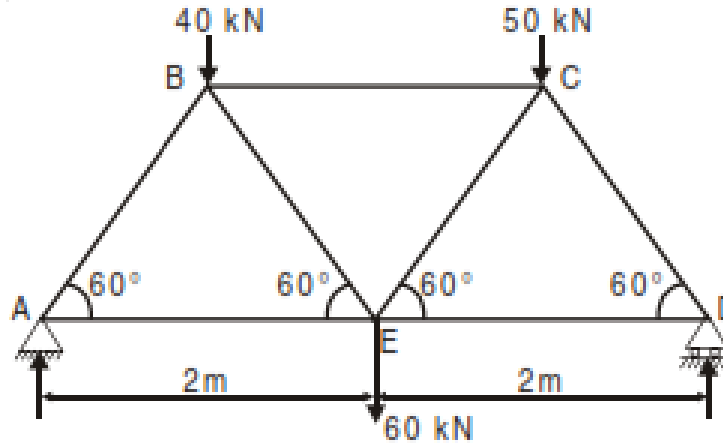

Figure.3.

Q-8

Attempt all questions

- (a) Find the centroid of the shaded section shown in the figure.4. (06)
- (b) Determine the moment of inertia of section shown in Figure.5. (08)

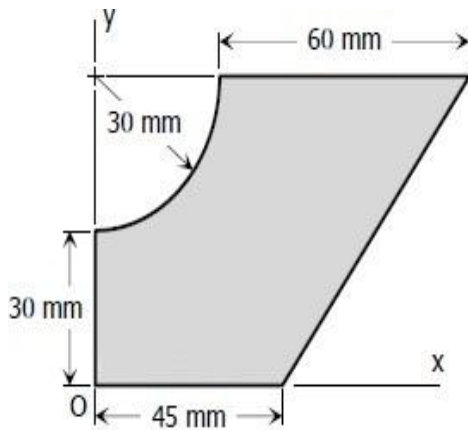

Figure.4.

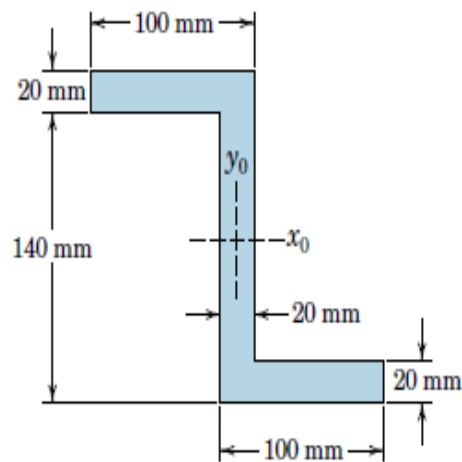

Figure.5.

